



**Impact Resistant, High Resolution Color Camera
especially suited for indoor use in low light conditions.**

- Low profile for discrete installation
- Impact resistant dome
- 480 TVL horizontal resolution / 50dB S/N
- 3-axis design for wall or ceiling mounting
- 0.9lx minimum illumination (F1.6)
- Auto-iris, aspheric 3.7 to 12mm lens for extended range
- AGC / BLC / ATW / and flicker correction
- Auto sensing for 24VAC or 12VDCV operation

High-Resolution DSP Color Dome Camera TND4104XS

SPECIFICATIONS

Power Source	AC24V (AC15V-27V) 60Hz±0.5Hz or DC12V (DC11V-35V)
Power consumption	AC : Approx. 2.5W or DC : Approx. 2.8W
Image pick-up device	1/3" color interline-transfer CCD
Effective picture element	768 (H) x 494 (V)
Scanning area	4.88mm (H) x 3.66mm(V)
Scanning system	2 : 1 interlaced
Scanning frequency	LL : 15.75kHz (H), 60Hz (V) INT : 15.734kHz (H), 59.94Hz (V)
Sync. System	AC :Line-lock / Internal (switchable) DC : Internal
Resolution	480TV lines (H) 350TV lines (V)
S/N ratio	50dB
Minimum illumination	0.9lx (F1.6 under incandescent lamp)
White balance	ATW/PUSH (switchable)
AGC (Automatic Gain Control)	Built-in (SENS UP switchable)
Backlight control (BLC)	Provided (switchable)
Power	Power cable (Non-plug)
VIDEO OUT terminal	BNC cable output VBS 1.0V (p-p) 75Ω
Lens	Varifocal lens F1.6 f=3.7 ~ 12mm
Angle of view	Horizontal 23.8° (TELE) ~ 76.1° (WIDE) Vertical 17.9° (TELE) ~ 55.8° (WIDE)
Dimensions	Diameter : 6 3/8" (162mm) Height : 3 5/8" (92.8mm)
Weight	Approx. 1.43lbs (650g)
Ambient temperature	-10°C ~50°C (14°F ~122°F)
Ambient humidity	30% ~ 90%
Accessories	Instruction manual, Warranty card, 2P Terminal block



PROFILE

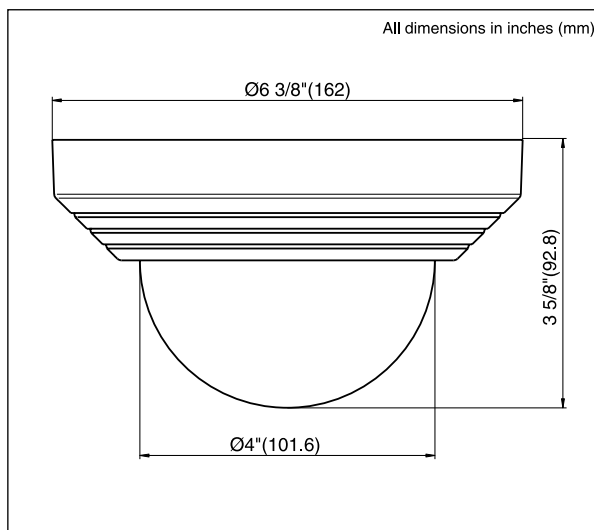

NOTE:-Design and specifications are subject to change without prior notice.
*Dimensions and weight are approximate.

ELMO CO.,LTD.(Head Office and Factory)'s QMS/EMS has been registered to ISO 9001 & ISO 14001: 2004.

ELMO is a trademark of ELMO COMPANY, LIMITED.

ELMO
FOCUS ON THE FUTURE

ELMO CO., LTD.

6-14, Meizen-cho, Mizuho-ku
Nagoya, 467-8567, Japan
E-mail : foreign-div@elmo.co.jp

Distributed by

Additional technical information is available from any of the following subsidiary companies:

ELMO USA Corp.

Headquarters
1478 Old Country Road
Plainview, NY 11803-5034, U.S.A.
Tel. (516) 501-1400 Fax. (516) 501-0429
E-mail : elmo@elmousa.com
Web : <http://www.elmousa.com>

West Coast Branch

Cypress Pointe Business Park
5676 Corporate Avenue
Cypress, CA 90630, U.S.A.
Tel. (714) 828-8457 Fax. (714) 828-8429

ELMO (Europe) G.m.b.H.

Neanderstr 18,
40233 Düsseldorf, Germany
Tel. (0211) 386470 Fax. (0211) 376630
E-mail : info@elmoeurope.com
Web : <http://www.elmoeurope.com>



This brochure is printed on recycled paper with soy ink.

Printed in Japan(A)9/2006